

Building Simulation 2017: “Comparison of chosen measures based on performance simulations using Low Order Models parametrized by archetype buildings and detailed building models in IDA ICE”

M. - A. Brüntjen, C. Fliegner, D. Koschwitz, Dr.-Ing. J. Frisch, Prof. Dr.-Ing. C. van Treeck
Lehrstuhl für Energieeffizientes Bauen (E3d)-RWTH - Aachen, Germany

Abstract

For future design of power and heat supply of urban districts, it is necessary to develop tools for estimating the thermal energetic behaviour and performance of city districts. These tools are under development by the Institute for Energy Efficient Buildings and Indoor Climate. TEASER is such a tool, which creates simulation models of archetype buildings, parameterized by only five input parameters. This enables a parameterisation of building performance models by statistical approaches with little effort. Therefore, the predicted energy losses and gains could deviate from the detailed parameterized models. The aim of this paper is to show the variance between recommended retrofit measures, estimated by two different approaches: the parameterisation of low order building models (LOM), which are set up with TEASER and simulated with Dymola, using the Modelica AixLib (2016) and the more detailed parametrisation building performance models in IDA ICE 4.7, based on on-site visit information like geometries, wall constructions and quality of envelope concerning infiltration.

Introduction

This paper deals with work within the RWTH Aachen University “EnEff: Campus - RoadMap RWTH Aachen” (EnEff: Campus) project aiming at developing a systematic road map towards a cost-effective reduction of the campus’ primary energy consumption. The project follows a systematic approach for deriving low-order dynamic building and distribution network energy performance models based on a geo-information database. The central objective of the project is to develop a road map for the reduction of the specific primary energy consumption with respect to the net leased area of buildings at RWTH Aachen University by 50% until 2025, based on the energy consumption of 2013/14. This goal will be achieved through an innovative global concept and will be determined by a newly developed and implemented comprehensive and transferable methodology for energy optimization of university campus buildings. Therefore, the current “in-situ” condition is systematically recorded in a database and presented using dynamic urban district simulation. The latter justifies the application of LOM. Using LOM for estimating the heating demand and heat load calculation leads to a high accuracy compared to detailed simulation

models (Lauster 2014a). Only slight deviations between the different approaches could occur. This yields to a reasonable approximation of the U-value and ventilation losses, which are mainly responsible for the heating demand. In contrast to the comparison of the heating load, the cooling load and cooling demand calculation differ more between the LOM and the detailed building model (Lauster 2014). This mainly results from a different degree of discretisation of the thermal masses. The discretisation and the given computational performance mostly influence the computational time of the building performance calculation with LOM. Considering the accurate estimation of the heating load and energy demand, Lauster showed that the LOM is suitable for city district simulation (Lauster 2014b). Furthermore, Schiefelbein (Schiefelbein 2015a) describes the generation of archetype buildings by means of statistical approaches. Therefore, only five input parameters are necessary: “building type, year of construction, floor height, number of floors, net floor area” (Schiefelbein 2015a). The application of LOM, parametrized by these five input parameters achieve a corresponding compliance for the thermal city district simulation with respect to measurements (Lauster 2013).

The usage of archetype buildings instead of buildings, parametrized by collected data from a local inspection means that if the thermal behaviour is compared, they should have the same construction properties. Consequently, the accuracy of the statistical approach for the determination of building parameters influences the distribution of identified losses. Due to this distribution and based on the construction, measures only concerning building construction will be proposed and further evaluated.

Methodology

This paper deals with a comparison of measures, which are determined by an application of LOM using archetype buildings and a detailed building simulation, which parameters are set by collected data. To compare these measures, three buildings of the RWTH Aachen University Campus are selected, representing three different types of buildings, concerning their building construction, year of construction and usage category. This comparison will show the variation of the calculated losses using two different ways of modelling and setting of parameters. The first method applies LOM based on “MultizoneEquipped.mo” from the Modelica AixLib

Library (AixLib 2016) within the simulation environment Dymola by using archetype buildings. The collected data are implemented as parameters into a detailed simulation model in IDA ICE 4.7. These data are e.g. the building construction, windows, zones and schedules.

The comparison is based on the following simulated values:

- transmission losses via exterior walls,
- transmission losses via windows,
- ventilation losses.

On basis of the percentage distribution of the single losses related to the absolute value, recommendations are proposed and the resulting differences will be discussed and evaluated.

TEASER

The “Tool for Energy Analysis and Simulation for Efficient Retrofit” (TEASER) is an open source Python-based software, developed by the Institute for Energy Efficient Buildings and Indoor Climate of the RWTH Aachen University (TEASER 2016). It is applied for the parametrization of building performance models, dealing with building data insufficiencies (which are usual on city district level). Therefore, TEASER uses statistical approaches based on the IWU building typology (Remmen 2016, Schiefelbein 2015b) for example. The minimum required input data consist of the following five parameters:

- year of construction/ year of retrofit,
- building height,
- net leased area,
- number of storeys,
- usage type.

Based on these parameters, envelope areas for exterior walls, windows, rooftop and basement are estimated. Furthermore, constructions of envelope structures are parameterised. This data enrichment provides a full dataset for the “MultizoneEquipped.mo” zone model. In this investigation, TEASER is applied to set up building models of the RWTH Aachen Campus.

LOM

Different techniques such as impulse response analysis or thermal network modelling are included in case of modelling the thermal building performance. The latter is used for the “MultizoneEquipped.mo” from the Modelica AixLib Library (AixLib 2016). It is a RC-Model based on the German Guideline VDI 6007-1 (VDI 6007 2012, Lauster 2014). Lauster modified the guideline model by adding an extra resistance, representing the thermal behaviour of window elements, as illustrated in figure 1 (Lauster 2014). Thus, the time constant of the the zone decreases.

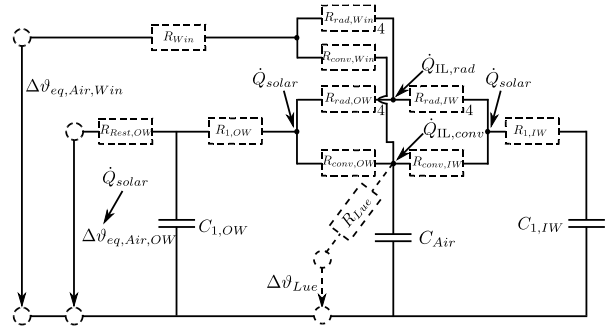

Figure 1: Low Order Model (Lauster 2014).

Depending on the usage type of the building, a varying number of zones represent the thermal building performance model. The accuracy of the tool chain, using TEASER for enriching the data to set the lumped parameters by the mentioned five parameters, was evaluated by Lauster (Lauster 2013) and assessed to be suitable for city district energy performance simulation.

Dynamic models implemented in IDA ICE

IDA ICE 4.7 is a building performance simulation software designed by EQUA Solutions (IDA ICE 2016). The implemented models enable investigations on the indoor climate and energy consumptions of entire buildings. IDA ICE provides two zone models, which differ in the modelling depth. The detailed zone model “CeDetZone” is used for indoor climate simulation tasks while the simplified zone model “CeSimZone” is used for energy consumption calculations (Bring et al. 2000). Both zones models have been successfully validated using the standard ASHRAE 140 (Equa Simulation AB 2010).

In this paper, IDA ICE is applied for energy performance simulations of RWTH Aachen buildings. Therefore, the “CeSimZone”-model is used, as illustrated in figure 2.

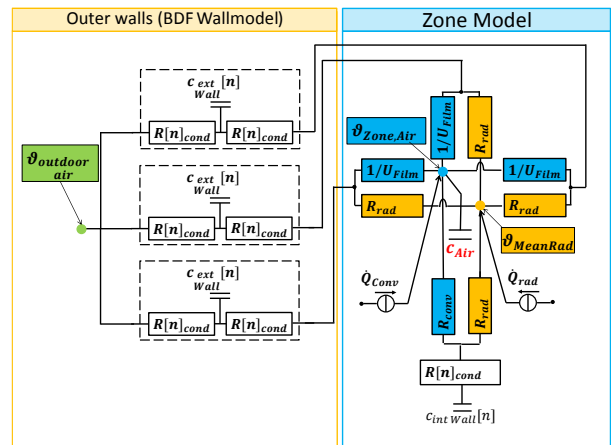

Figure 2: Network model of the IDA ICE 4.7 “CeSimZone”-model.

“CeSimZone” is based on two internal capacities for describing the air load and internal masses such as internal walls or furniture. Here, internal walls are assumed to be adiabatic and, thus, they do not contribute to the heat loss calculation. Outer walls are connected to the outside,

being handled separately in modular sub-models. The standard wall model in IDA ICE 4 is the “BDFWall”-model. This model uses a FORTRAN subroutine for numerical optimization, which allows to use a Backward Euler-Method or a Midpoint-Method as an adaptive integration method. Both are implicit integration methods and provide a high numerical stability, but generate longer computation times. In IDA ICE, the Backward Euler method is the default and used for this investigation. The “CeSimZone”-model uses two energy balances to calculate the mean radiant temperature and the indoor air temperature. These two resulting equations are connected via heat balances for zones surfaces. Convective heat fluxes from wall surfaces, heating and cooling devices and enthalpy fluxes due to infiltration or required air exchange are considered for the calculation of the indoor air temperature. Heat transfer coefficients can be calculated by various models with different levels of detail. Starting with constant values, IDA-ICE offers an external FORTRAN subroutine “U_Film” calculating for instance detailed natural convection. These algorithms consider the temperature difference between surface and air, the slope of the surface and the hourly air exchange rate for calculating the heat transfer coefficient (Bring et al. 2000). The mean radiant temperature is mainly influenced by heat fluxes from heating and cooling devices, wall surfaces and lighting. Direct, diffuse and reflected diffuse shortwave radiation are absorbed or reflected at the wall surfaces.

Test cases

For this investigation, three RWTH Aachen University facilities are chosen, which differ, in some characteristics such as usage type, building structure typology, net leased area and year of construction. One of the main common features is their high energy consumption with respect to the net leased area.

For determination of the heat loss distribution by LOM, three buildings are implemented and parametrized by TEASER and simulated with Modelica. To apply a detailed performance simulation using IDA ICE, the geometry, building construction, usage and boundary conditions of zones and rooms have to be collected. It should be mentioned, that the estimated ventilation rate is approximated by a detailed examination of the envelope quality and based on interviews with facility managers who gave information about the actual ventilation strategies.

Administration building

The “Administration building” is a typical non-residential building, mainly used as office building with small parts as lecture halls, shown in figure 3.



Figure 3: Street view of the “Administration building”

Table 1 provides information about the thermal properties of this building.

Table 1: Building information about the “Administration building”

Building information	Units	Values
year of construction	[-]	1959
net leased area	[m ²]	10695
usage type	[-]	administration building
height of building	[m]	28.84
number of stories	[-]	8
recorded wall area	[m ²]	approx. 5582
recorded window area	[m ²]	approx. 1730
recorded wall U-values	[W/(m ² K)]	0.23 -2.5
recorded window U-values	[W/(m ² K)]	2.7
yearly energy consumption	[MWh/a]	946

The first five parameters, mentioned in table 1 are used as input data for TEASER to set up the parametrization of the LOM. The values listed below help to accomplish an implementation of the envelope construction in IDA ICE.

The administration building has no mentionable air handling units, although the envelope shows significant leaks in some cases. Hence, the ventilation rate is assessed to approximately 0.8 air change per hour (ACH), according to DIN EN 12831 supplement 2 (DIN EN 12831 B1.2. 2011). Taking offices, corridors and lecture halls into consideration, the schedules for occupancy, equipment and light are oriented according to the recommendation of SIA 2024 (SIA 2024. 2006). Values for internal gains were recorded and estimated as illustrated in table 2.

Table 2: Specific values for zone parametrization of the “Administration building”

	Occupant	Light	Equipment
Zone	[no./m ²]	[W/m ²]	[W/m ²]
Office	0.1	13	14.5
Corridor	0	5	0
Lecture halls	0.45	7.73	10.3

Due to insufficient information about the window opening strategies they are not modelled. Thus, a constant air change per hour of 0.8 ACH is applied.

Historical building

This test case refers to older buildings of RWTH Aachen University, characterized by a massive wall construction, illustrated in figure 4. Furthermore, three main usage types are allocated to this building: laboratories, offices and lecture halls.



Figure 4: Street view of the “Historical building”

In table 3, relevant thermal building properties are summarized.

Table 3: Building information about the “Historical building”

Building information	Units	Values
year of construction	[-]	1910
net leased area	[m ²]	3184
usage type	[-]	research facility for: educational sciences, art and design
height of building	[m]	15.11
number of stories	[-]	4
recorded wall area	[m ²]	approx. 1888
recorded window area	[m ²]	approx. 1321
recorded wall U-values	[W/(m ² K)]	1.0
recorded window U-values	[W/(m ² K)]	1.9
yearly energy consumption	[MWh/a]	1068

As in the previous case, the first five parameters listed in table 3 are used for data enrichment to setup the LOM in Dymola. whereas other information are applied to implement a detailed model in IDA ICE. Furthermore, it was noticed that corridors are ventilated by natural ventilation due to tilted window opening strategies during the whole day, even during the heating period. The offices used to follow the same strategy, although, this only applies during working time. Both opening strategies are assessed as shown in figure 5.

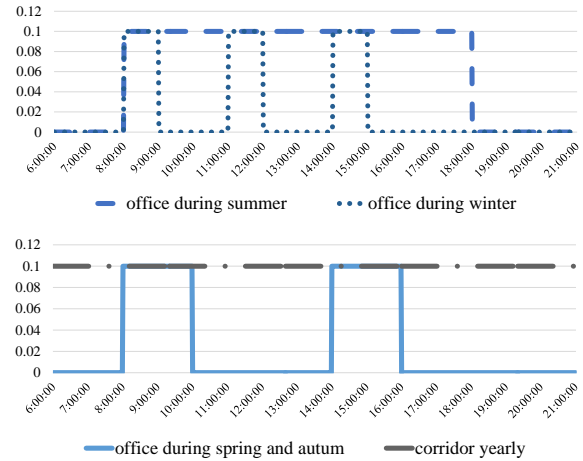

Figure 5: Window opening strategies for the “Historical building”

As illustrated in figure 5, five different window opening strategies are considered. The strategies for the offices are seasonal, like the dotted lines illustrate. Furthermore, the corridors used to be open during the whole day, as represented by the long dashed line for the constant value of 0.2 (the window model in IDA ICE needs values between 0 and 1 for its opening strategies, so that 0.2 is considered as tilted window). The values for calculating the internal gains are listed in table 4.

Table 4: Specific internal gain values for zone parametrization of the “Historical building”

	Occupant	Light	Equipment
Zone	[no./m ²]	[W/m ²]	[W/m ²]
Office	0.1	13	14.5
Corridor	0	5	0
Laboratories	0.1	13	18

Research facility

In figure 6, a part of the “Research facility” is illustrated. This kind of construction type is typical for the late 1970s. The usage type differs mainly between laboratories and offices.



Figure 6: Three building parts of the “Research facility”

In table 5, the dominant thermal building properties are listed.

Table 5: Building information about the “Research facility”

Building information	Units	Values
year of construction	[-]	1978
net leased area	[m ²]	6110
usage type	[-]	research facility for: chemistry, physics and biology, pharmacy and workshop
height of building	[m]	min.11; max. 20
number of stories	[-]	min. 2; max. 5
recorded wall area	[m ²]	sum: 2453
recorded window area	[m ²]	sum: 2562
recorded wall U-values	[W/(m ² K)]	1.4 – 2.98
recorded window U-values	[W/(m ² K)]	1.3 – 2.8
yearly energy consumption	[MWh/a]	6196

All building parts were constructed in 1978. The lecture halls are ventilated by an air handling unit, laboratories only by exhaust air ventilation. The parameter settings for the air change rates of the laboratories follow the standard DIN V 18599 -10 (DIN V 18599-10 2016).

As in the case of the detailed model setup for the “Historical building”, the schedules are based on the documentation from on-site inspection or follows SIA 2024 (SIA 2024, 2006). It was observed that offices are mainly ventilated by natural ventilation due to tilted window opening strategies. Even during the heating period, tilted windows were noticed. Therefore, a different opening strategy for offices, as illustrated in figure 5, is assessed. For internal gains, the listed data in

table 6 are implemented in the detailed model using IDA ICE as well as related schedules.

Table 6: Specific values for zone parametrization of the “Research facility”

	Occupant	Light	Equipment
Zone	[no./m ²]	[W/m ²]	[W/m ²]
Office	0.1	13	14.5
Corridor	0	5	0
Laboratories	0.1	13	18
Lecture halls	0.45	7.73	10.3

Effort for data acquisition and implementation

To create a thermal simulation performance model of a building, parameters have to be collected during on-site inspections. The two different approaches need a different amount of time for data acquisition, which will be subsequently elaborated. The previously unknown parameters such as height and the number of storeys had to be collected by an on-site inspection. The time for the request to the Facility Management is neglectable. The estimation of the height and number of storeys for all buildings took about 45 min per building.

Concerning the detailed building performance simulation model, the required time to obtain the data, is listed in table 7.

Table 7: Approximation of time for acquisition and implementation of the required data for the detailed building performance simulation model

Building	Historical building	Adminis-tration building	Research facility
Needed time in	[h]	[h]	[h]
Review of building geometry (height of building and zones)	19	15	27
Zone data (usage, person, equipment)	6	4	16
implementation of building and zone geometry	53	28	72
Total	78	47	115

Depending on the complexity of the geometry, the effort of collecting and reviewing data rises as well as the time for a model implementation. The latter is among others related to the computing performance with regard to 3D visualisation, which is taken into account for related data quality checks.

Retrofit measures

There are different types of retrofit measures to lower the heating losses which depend on the facade type, as described in table 8.

Table 8: Retrofit measures depending on the facade type

static type	construction type		measure
self-supporting facade	massive construction	natural stone and brick masonry	thermal insulation system
			curtain wall
			thermal insulation system + window replacement
			curtain wall + window replacement
		protected monuments	interior insulation
			interior insulation + window replacement
			window replacement
			window replacement
	skeletal construction	massive external wall	thermal insulation system
			curtain wall
			thermal insulation system + window replacement
			curtain wall + window replacement
			window replacement
			window replacement
non self-supporting facade	skeletal construction	pillar facade	thermal insulation system
			window replacement
			thermal insulation system + window replacement
		banner facade	prefabricated facade elements
			thermal insulation system
			thermal insulation system + window replacement
	element facade	replacement of all elements	

Besides the refurbishment of the facade construction, other possibilities could be realized. It is possible to reduce the leak area in the envelope, for instance to reduce ventilation losses due to infiltration.

Limitations

The objective of this investigation intends mainly in showing how a non-critical application of each implementation affects the recommendation for building envelope retrofit measures using two different approaches of creating thermal performance models. Considering the usage of TEASER or rather archetype buildings, assumptions for setting up the LOM are indispensable and shall be mentioned:

- Measurement of high-resolution energy performance is not available, as well as the allocation of the energy consumption. Therefore, the detailed building performance model, implemented in IDA ICE (based on real geometry and on-site inspection data sets), is the reference for a demand calculation and the allocation of the energy demand/consumption.
- Low Order Models used for this investigation are supplied by the AixLib library version “The Modelica _Annex60_ library”. This library is currently still under development.
- To parameterize a building model by archetype buildings, default values are used. For instance while estimating the U-value depending on the year of construction, a massive construction type is set as default for walls.
- Window opening strategies, which are implemented in the detailed building performance model, were set only for office rooms, lecture halls or corridors. Only those were characterized by schedules based on the on-site inspection.
- All performance simulations depend on the same climate profile of 2013 to ensure comparability with respect to the heat consumption (Schneider 2013).

Results

Table 9 lists the heat consumption from 2013, the estimated heating demand with LOM using archetype buildings and the calculated demand based on the detailed model using IDA ICE, which is set up with data from the on-site inspection. The last row illustrates the percentage deviation of the calculated heat demand in comparison to the energy consumption.

Table 9: Heat demand vs. heat consumption

Building	Historical building	Administration building	Research facility
	[MWh]	[MWh]	[MWh]
Heat consumption (2013)	1068	964	6196
Heat demand (TEASER+LOM)	923	1069	1908
Heat demand (IDA ICE)	1048	943	6585
Percentage deviation from the estimated energy demand with the LOM to the yearly energy consumption	13.6%	10.9%	69.2%
Percentage deviation from the estimated energy demand with the detailed model to the yearly energy consumption	1.9%	2.1%	6.3%

The energy demand calculation for the “Administration building” and the “Historical building” using an archetype building approach (to parameterize LOM) corresponds with the energy consumption as illustrated in table 9. But there can be large differences while applying archetypes and default values. This can be seen in the comparison between the energy demand calculation and the energy consumption for the “Research building”, which differs for about 70% percent. It should be mentioned that for each detailed simulation result, the energy demand calculations are in good approximation to the heat consumptions.

Allocation of energy losses via the envelope

For all presented facilities, measured data are scarce and, therefore, it is difficult to determine the composition of the energy consumption. For this purpose, the thermal building performance simulation is a helpful tool to estimate the distribution of the energy losses and to recommended retrofit measures. Figure 7 shows the estimated losses via the envelope for each building.

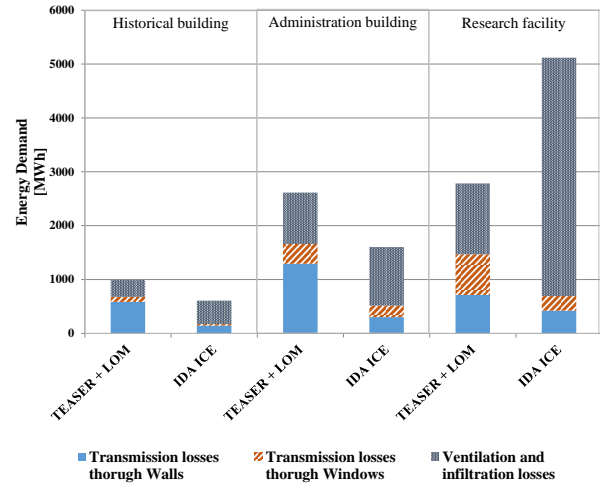

Figure 7: Distribution of heat losses (transmission through wall and window, ventilation) for each building; estimated with TEASER and LOM and IDA ICE

As mentioned before, the determined energy demand for the “Historical building” and the “Administration building” meet the yearly energy consumption. In figure 8 to 10, pie charts are used to visualize the allocation of estimated losses by TEASER, LOM and IDA ICE. These charts pose a good method to point out efficient recommendations of retrofit measures.

Derived retrofit measures for the “Historical building”

Figure 7 and Figure 8 show the allocation of the energy losses estimated with TEASER + LOM and IDA ICE.

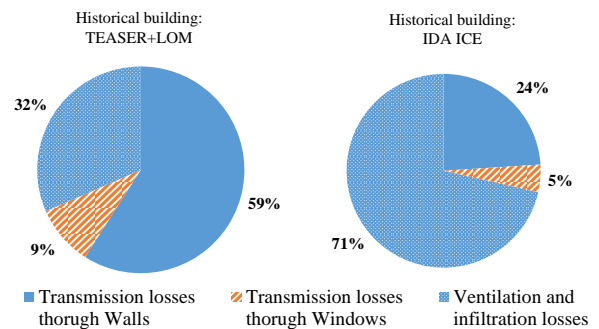

Figure 8: Allocation of losses (transmission through wall and window, ventilation) for the “Historical building” estimated with TEASER, LOM and IDA ICE

The main cause for the energy losses, calculated with TEASER are the transmissions via the walls. The “Historical building” is constructed of massive natural stone masonry and belongs to the protected monuments. Therefore, interior wall insulation has to be chosen, as the external walls must not be modified.

The results of the heat loss calculations are represented in the right pie chart in figure 8 and show the allocation of the calculated energy demand of the “Historical building”, where the main losses are ventilation losses due to tilted window opening strategies. These are caused by high internal gains and poor regulation of water radiator

thermostat valves. Resulting from this calculation, the most effective retrofit measure for this building is the use of automatic window openers. A further measure is the optimization of the hydraulic control to avoid tilted windows caused by the occupants.

Derived retrofit measures for the “Administration building”

The calculation based on archetypes and defaults in TEASER + LOM illustrated in figure 7 and figure 9.

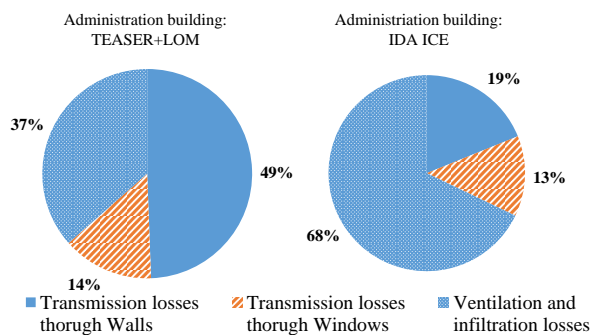

Figure 9: Allocation of losses (transmission through wall and window, ventilation) for the “Administration building” estimated with TEASER, LOM and IDA ICE

It is obvious, that the main losses are due to transmission via walls and windows. Hence, the retrofit measures would be to replace the windows and integrate a more effective insulation system. On the other hand, the on-site inspection and the IDA ICE model calculation indicate ventilation losses as predominant heating losses. As mentioned above, the envelope exhibits defects so that the infiltration is larger as usual. Derived measures for reducing the ventilation losses could be achieved by sealing the joints between window casement and frame or between frame and window soffit.

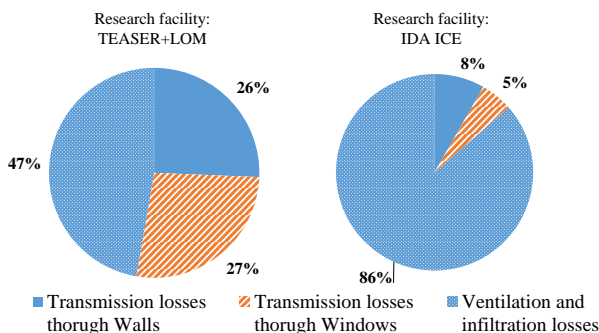

Figure 10: Allocation of losses (transmission through wall and window, ventilation) for the “Research facility” estimated with TEASER, LOM and IDA ICE

Derived retrofit measures for the “Research facility”

Results determined by TEASER + LOM are illustrated in figure 7 and figure 10. The left pie chart in figure 10 points out, that heating loss due to ventilation and through walls is in the same range. It should be mentioned that the calculated energy demand does not correlate with the

energy consumption in table 9. In case retrofit measures have to be recommended, the window and facade have to be refurbished and, thus, the infiltration rate will decrease.

The calculation of the energy demand for the “Research facility” with IDA ICE corresponds to the energy consumption as shown in table 9. The window opening strategies and the exhaust air ventilation for the laboratories yield to ventilation losses up to 85%. Based on these losses, retrofit measures concerning efficient air handling units seem to be necessary.

Discussion

All calculations of the energy demand and losses by the application TEASER+LOM are based on a minimal input parameter set. Using this minimal data set and statistical approaches to predict the performance of buildings, the implemented model has to correspond with the approach. Otherwise, the accuracy of the performance deviates from the real building characteristics, as illustrated in table 9. Not only characteristics for estimating losses, but also internal gains, have to be determined correctly. Otherwise, energy demands could be estimated correctly, in contrast to the energy consumption, as table 9 and figure 7 demonstrate for the “Historical building” and “Administration building”. The internal gains generated with LOM might be higher than the implementation IDA ICE delivers. A further critical point is the determination of envelope areas, based on the statistical approach, as often different values are estimated.

All recommended retrofit measures, determined with TEASER and LOM, lead to a refurbishment of the envelope like replacing thermal insulation systems or windows. In contrast, the detailed models propose a sealing of joints or refurbishment of the ventilation system by optimized ventilation strategies, for example.

Conclusion

TEASER is an application for enriching data, based on a statistical approach, which can be used for parameterization of LOM. The combination of both applications is helpful to set up performance simulation models for city district heating, even if data is scarce. On the one hand, table 7 clarifies that the effort of data acquisition for TEASER+LOM is disproportional to the one for the detailed model in IDA ICE. On the other hand, if retrofit measures have to be declared, the investigations show, that on-site inspections are necessary to collect data, which predict losses and gains very close to the characteristics of real buildings. Concerning investment costs for refurbishment like replacing windows, the costs for on-site inspections will never be in proportion to the investment costs. Especially, if a high cost refurbishment was estimated by using archetype buildings and low cost retrofit measures could be determined. A simple sealing of joints could reduce more energy losses than the replacement of windows or insulation system, as the results for the “Administration building” indicate. Hence, due to the usage of archetype buildings, it is difficult to reproduce the heat loss allocations and recommend

retrofit measures. Nevertheless, this comparison of recommended retrofits is based on the combined application of TEASER and LOM. Further investigations showed that these tools are helpful to predict the performance of city districts and for analysing the city district heating supply if archetype buildings are used to parameterize LOM. It should be mentioned that the LOM could be parametrized with more information, for instance with acquisition data. Further investigations will be applied to define a higher accuracy of the LOM with less effort to invest.

Acknowledgement

We gratefully acknowledge the financial support of this work by the German Federal Ministry of Economics and Energy (BMWi) as per resolution of the German Parliament under the funding code 03ET1260A.

References

- AixLib (2016), Energy Efficient Buildings and Indoor Climate, AixLib Modelica libraries, <https://github.com/RWTH-EBC/AixLib> (2016-08-04).
- DIN 12831 Beiblatt 2 (2011), DIN Deutsches Institut für Normung e. V., Heizungsanlagen in Gebäuden, Verfahren zur Berechnung der Norm-Heizlast, Beiblatt 2: Vereinfachtes Verfahren zur Ermittlung der Gebäude-Heizlast und der Wärmeeintragleistung.
- DIN V 18599 -10 (2016), DIN Deutsches Institut für Normung e. V., Energetische Bewertung von Gebäuden – Berechnung des Nutz-, End- und Primärenergiebedarfs für Heizung, Kühlung, Lüftung, Trinkwarmwasser und Beleuchtung – Teil 10: Nutzungsrandbedingungen, Klimadaten. Tabelle A.36
- IDA ICE (2016), EQUA Simulation AB, [http://equa.se/en/ida-ice\(2016-12-04\)](http://equa.se/en/ida-ice(2016-12-04)).
- Lauster, M., Teichmann J., Fuchs M., Streblow R., Mueller D. (2013), Low order thermal network models for dynamic simulations of buildings on city district scale, Building and Environment, Volume.
- Lauster, M., Brüntjen M.-A., Leppmann H., Fuchs M., Teichmann J., Streblow R., van Treeck C. and Müller D. (2014), Improving a low order building model for urban scale application, 5. German –Austrian of IBPSA, Human Center Building(s).
- Loga, T., N. Diefenbach, J. Knissel, and R. Born. (2005). Entwicklung eines vereinfachten statistisch abgesicherten Verfahrens zur Erhebung von Gebäudedaten für die Erstellung des Energieprofils von Gebäuden. Online resource: http://www.iwu.de/fileadmin/user_upload/dateien/energie/werkzeuge/iwu-kurzverfahren_energieprofil-enderbericht.pdf (2016-11-25).
- Remmen, P., Cao, J., Ebertshäuser S., Frisch J., Lauster M., Maile T., O'Donnell J., Pinheiro S., Rädler J., Streblow R., Thorade M., Wimmer R., Müller D., Nytsch-Geusen C., van Treeck C. (2015). An open framework for integrated BIM-Based Building Performance Simulation using Modelica. 14th Conference of IBPSA, Hyderabad, India, Dec. 7-9, 2015. p. 379-386.
- Remmen P., Lauster M., Mans M., Osterhage T. and Dirk Müller(2016), CityGML Import and Export for dynamic building performance simulation in modelica, In the 6th German-Austrian IBPSA Conference. Online resource: <http://www.ibpsa.org/proceedings/BSO2016/p1047.pdf> (2016-11-21).
- Schiefelbein J., Javadi A., Lauster M., Remmen P., Streblow R., Müller D. (2015a), Development of a city information model to support data management and analysis of building energy systems within complex city districts, International Conference Future Buildings & Districts Sustainability from Nano to Urban Scale Lau-sanne, Switzerland , CISBAT 2015, ISBN 978-2-9701052-2-0, EPFL-CONF-213441, p. 949-954, Online resource: <http://dx.doi.org/10.5075/epfl-cisbat2015-949-954> (2016-11-21).
- Schiefelbein J. and Diekerhof M., Javadi A., Bode G., Streblow R., Müller D., Monti A. (2015b), Development of a tool chain for complex city district energy system modeling and simulation, 14th International Conference of IBPSA Building Simulation 2015. Conference Proceedings. Online resource: December 7 - 9, 2015, Hyderabad, India, Ghent: IBPSA, 2015 http://www.ibpsa.org/?page_id=619 ISBN: 978-93-5230-118-8 S. 1774 -1781.
- Schneider, C., Ketzler, Gunnar (2014) [Hrsg.]: Klimamessstation Aachen-Hörn - Monatsbericht (01/2014), RWTH Aachen, Geographisches Institut, Lehr- und Forschungsgebiet Physische Geographie und Klimatologie ISSN 1861-4000
- SIA 2024 (2006), Swiss Society of Engineers and Architects. Guidelines for standard internal loads for energy and building services engineering (SIA 2024). Zurich: SIA..
- TEASER (2016), Energy Efficient Buildings and Indoor Climate, TEASER – “Tool for Energy Analysis and Simulation for Efficient Retrofit” released, <https://www.ebc.eonerc.rwth-aachen.de/go/id/gips/?lidx=1#aaaaaaaaaagipu> (2016-08-04).
- VDI 6007-1 (2012), German Association of Engineers, Calculation of transient thermal response of rooms and buildings - Modelling of rooms 91.140.10.